

PLUG IN(fill)

reimagining the role of mobile housing

Suburban sprawl creates fragmented cities through growth at the fringe. How can alternative housing strategies be implemented in order to counteract the commuter based lifestyle of suburbia?

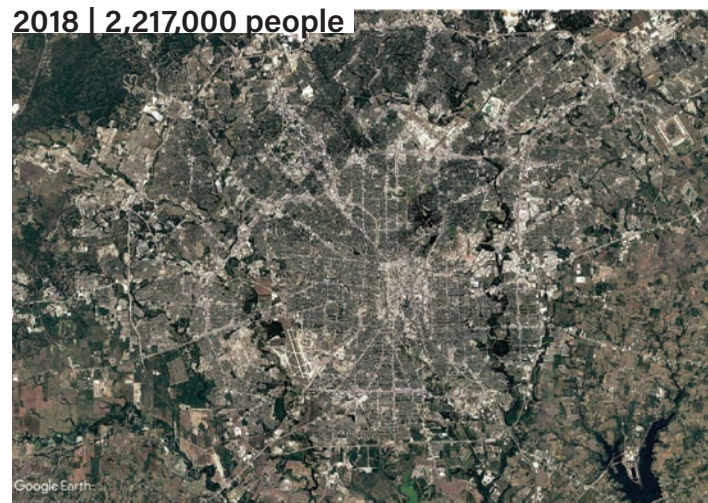
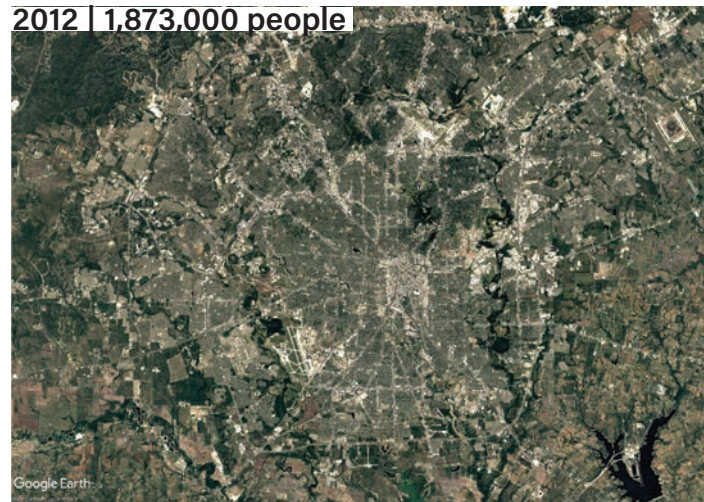
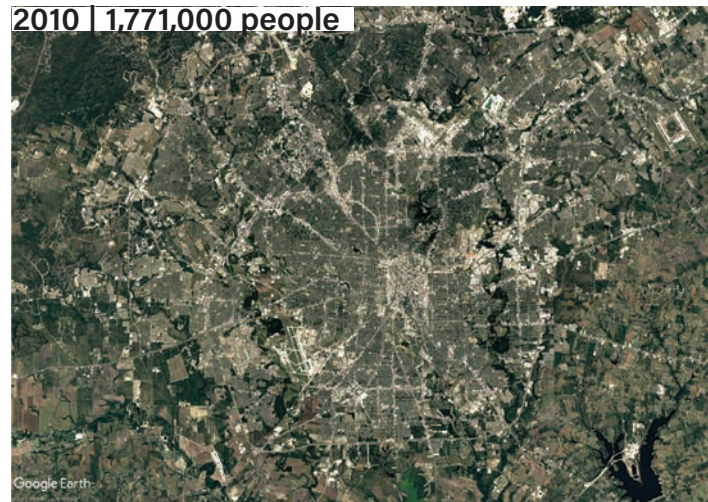
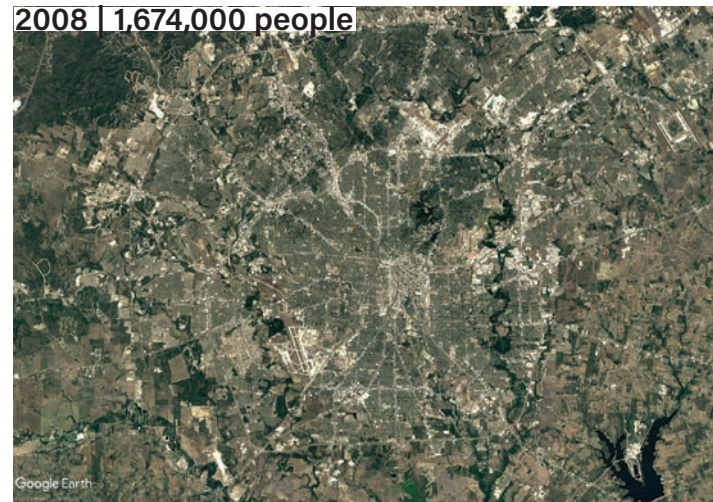
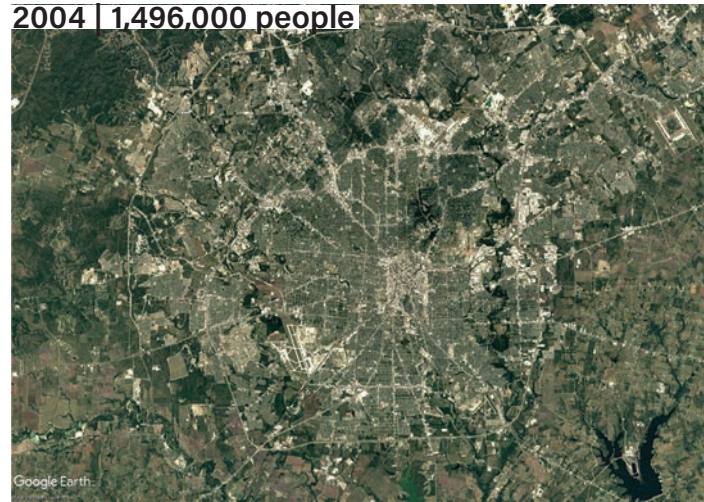
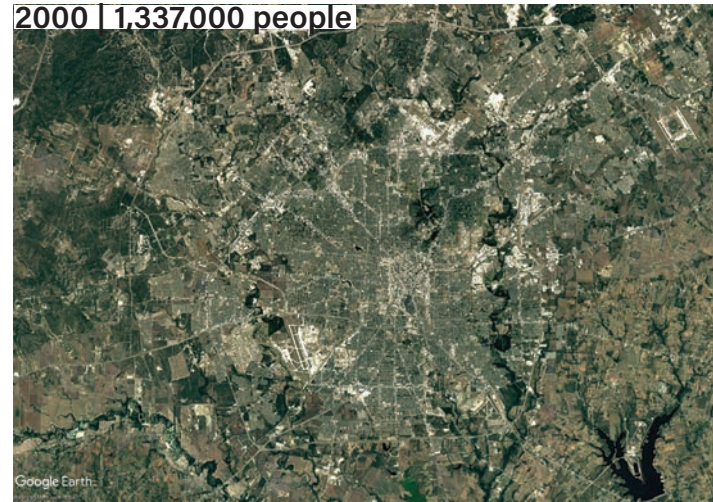

city growth | 2002 - 2022

2000 | 1,337,000 people

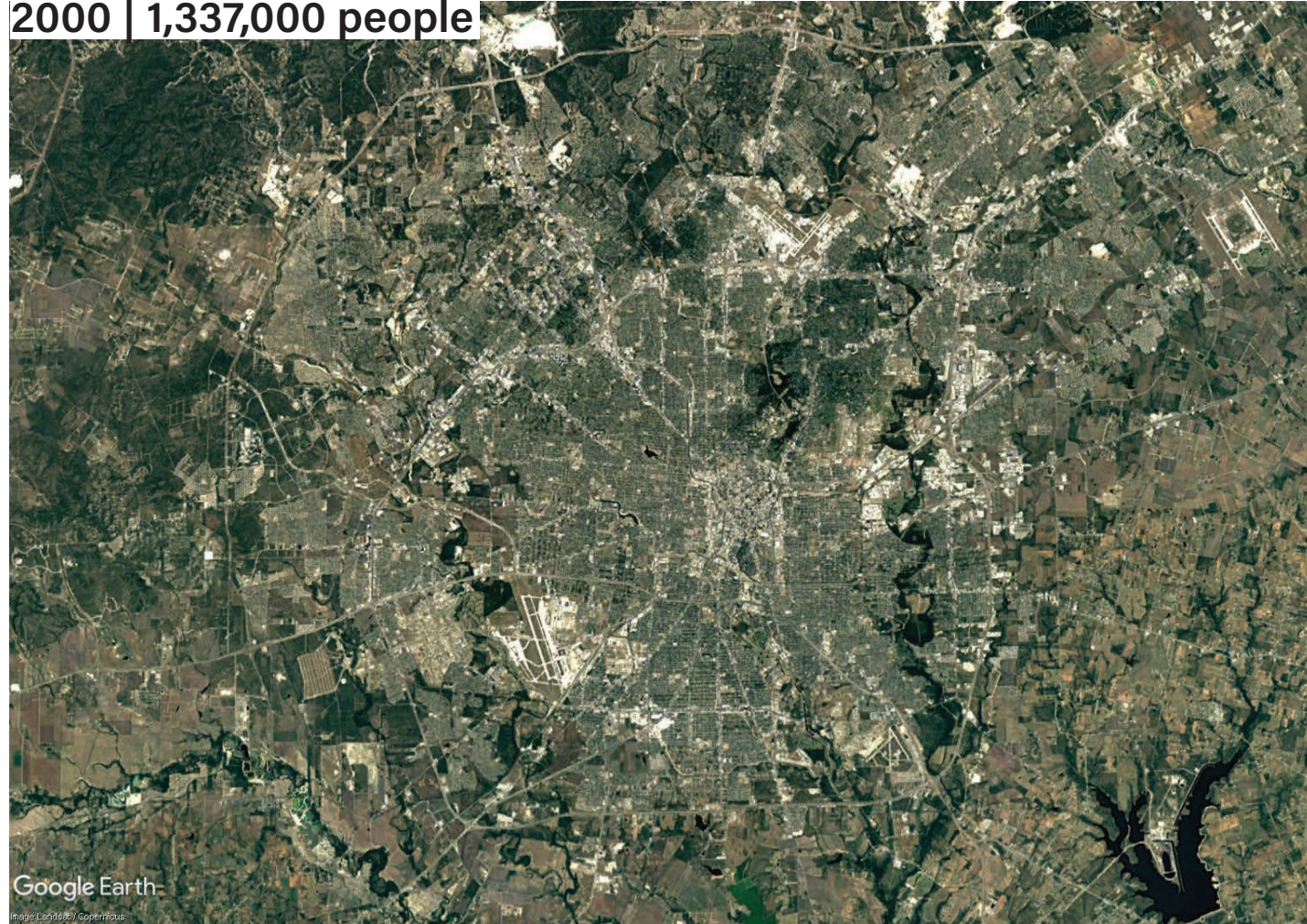

2022 | 2,413,000 people

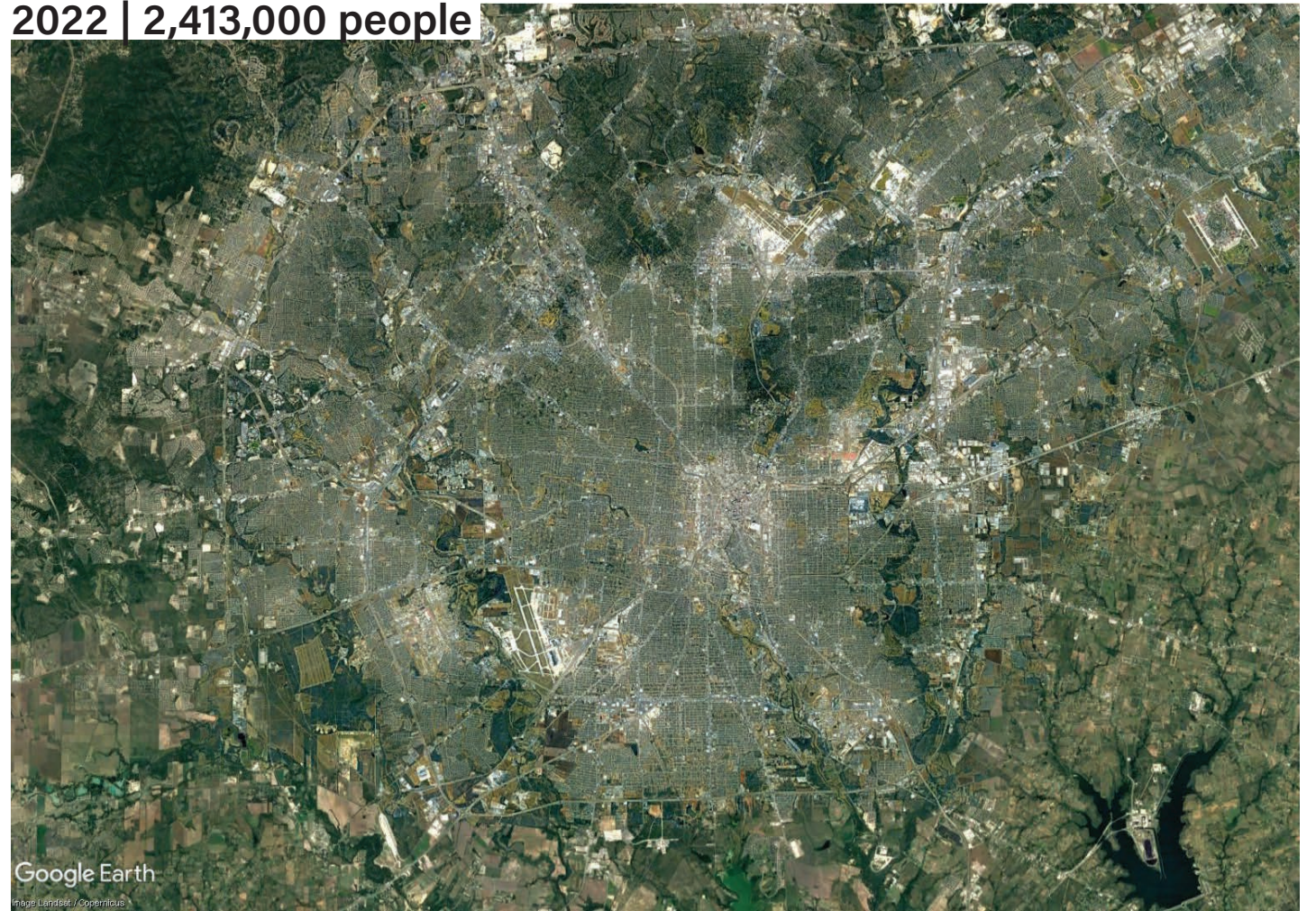

city growth | 2002 + 2022



urban core



urban core + parking

■ surface parking

■ parking structure

urban core + parking





- 01 surface parking (lot)
- 02 surface parking (infill)
- 03 parking structure (stacked)
- surface parking
- parking structure

urban core + parking typologies

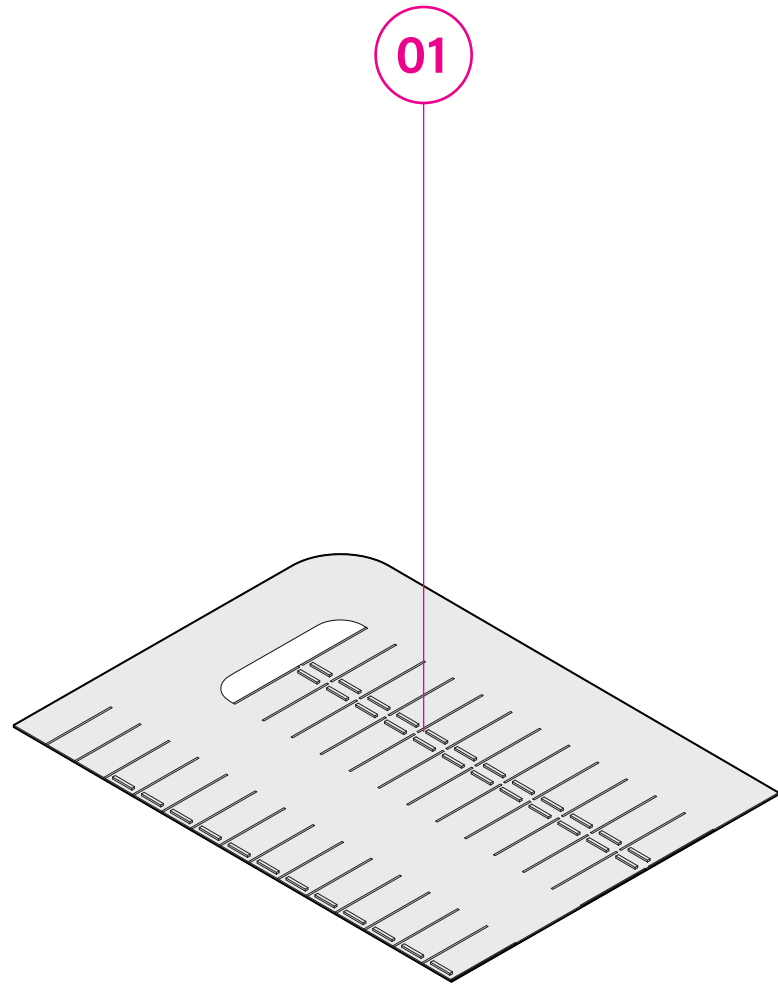

01 surface parking (lot)

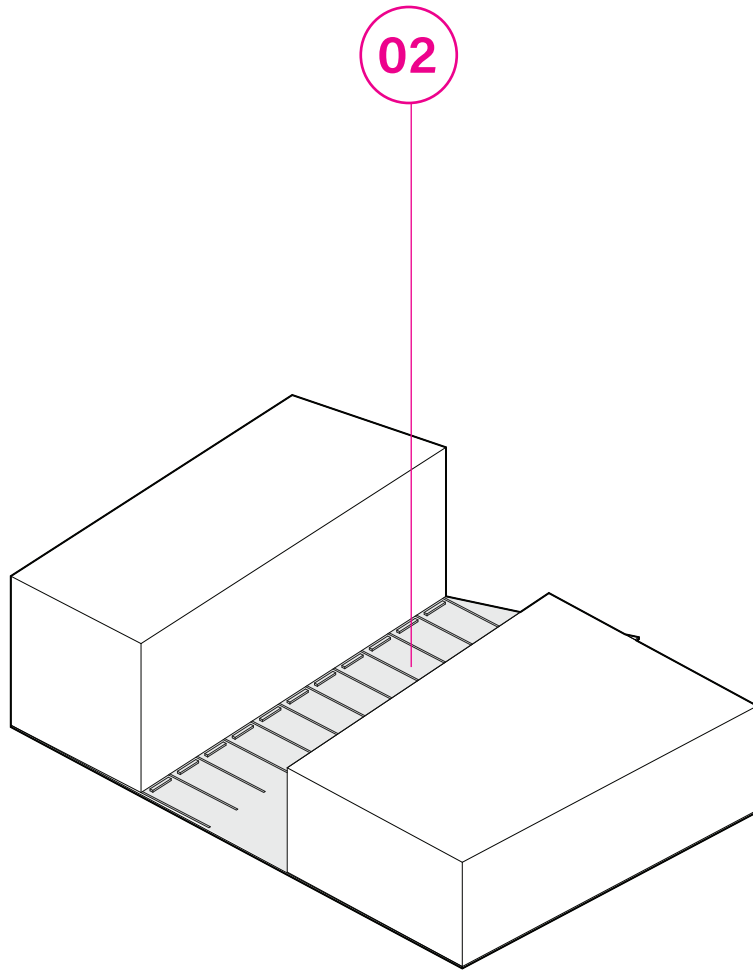

02 surface parking (infill)

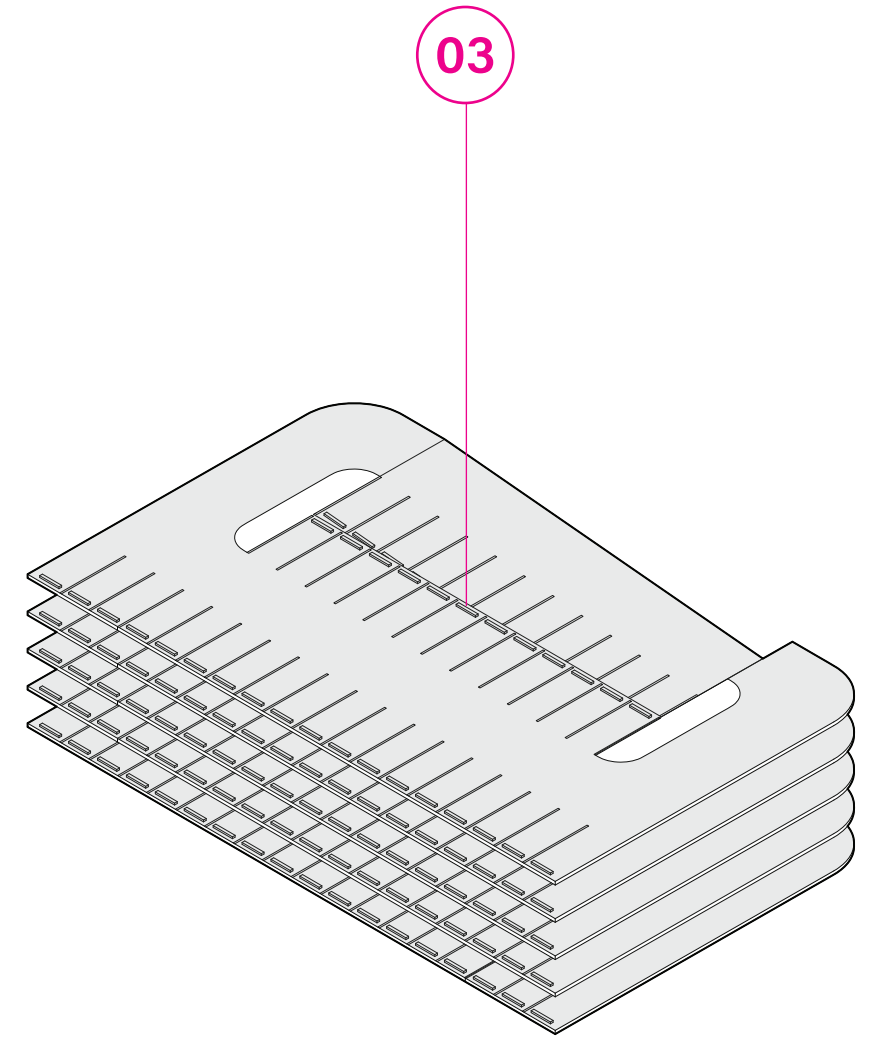

03 parking structure (stacked)

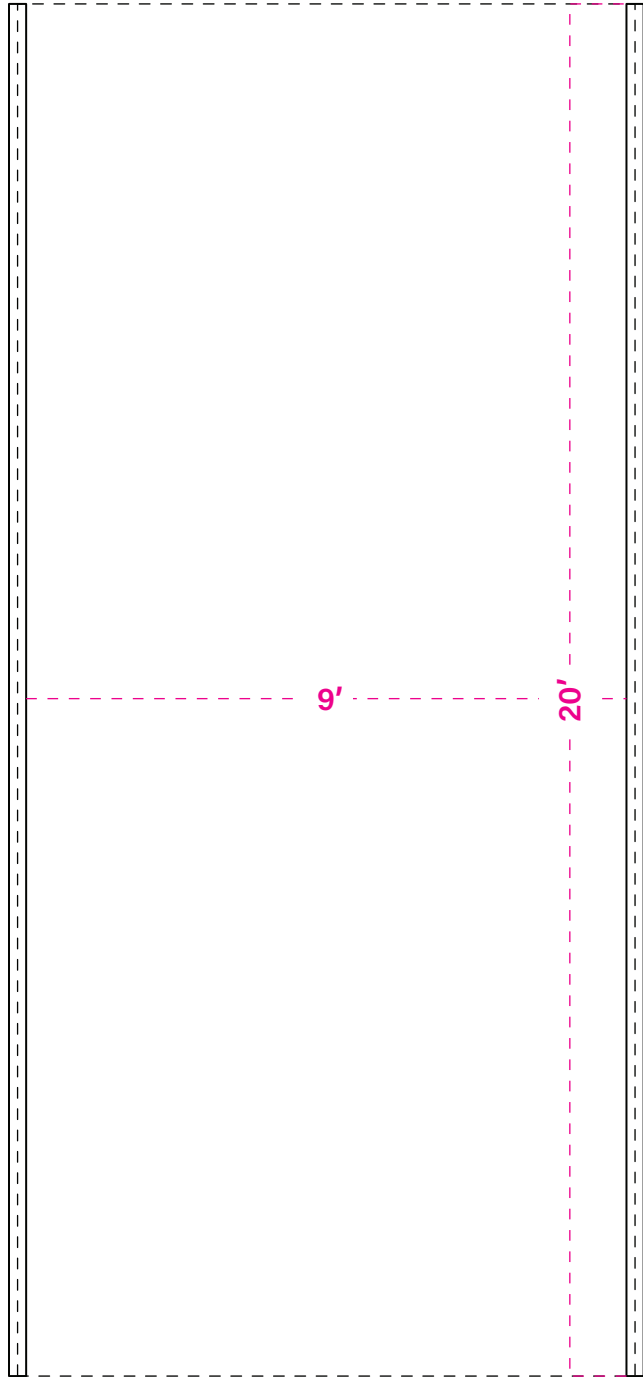

01 standard parking dimensions
standard parking dimensions are 9' wide and 20' long

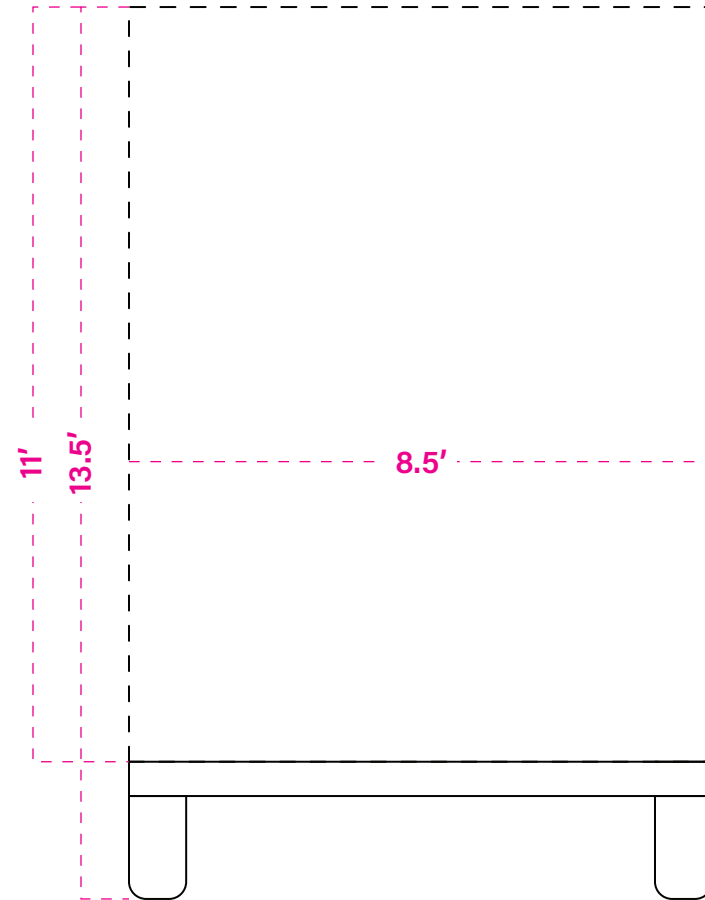

02 maximum trailer dimensions
maximum trailer dimensions (without permit) are 40' long and 8.5' wide, with a total height no taller than 13.5'

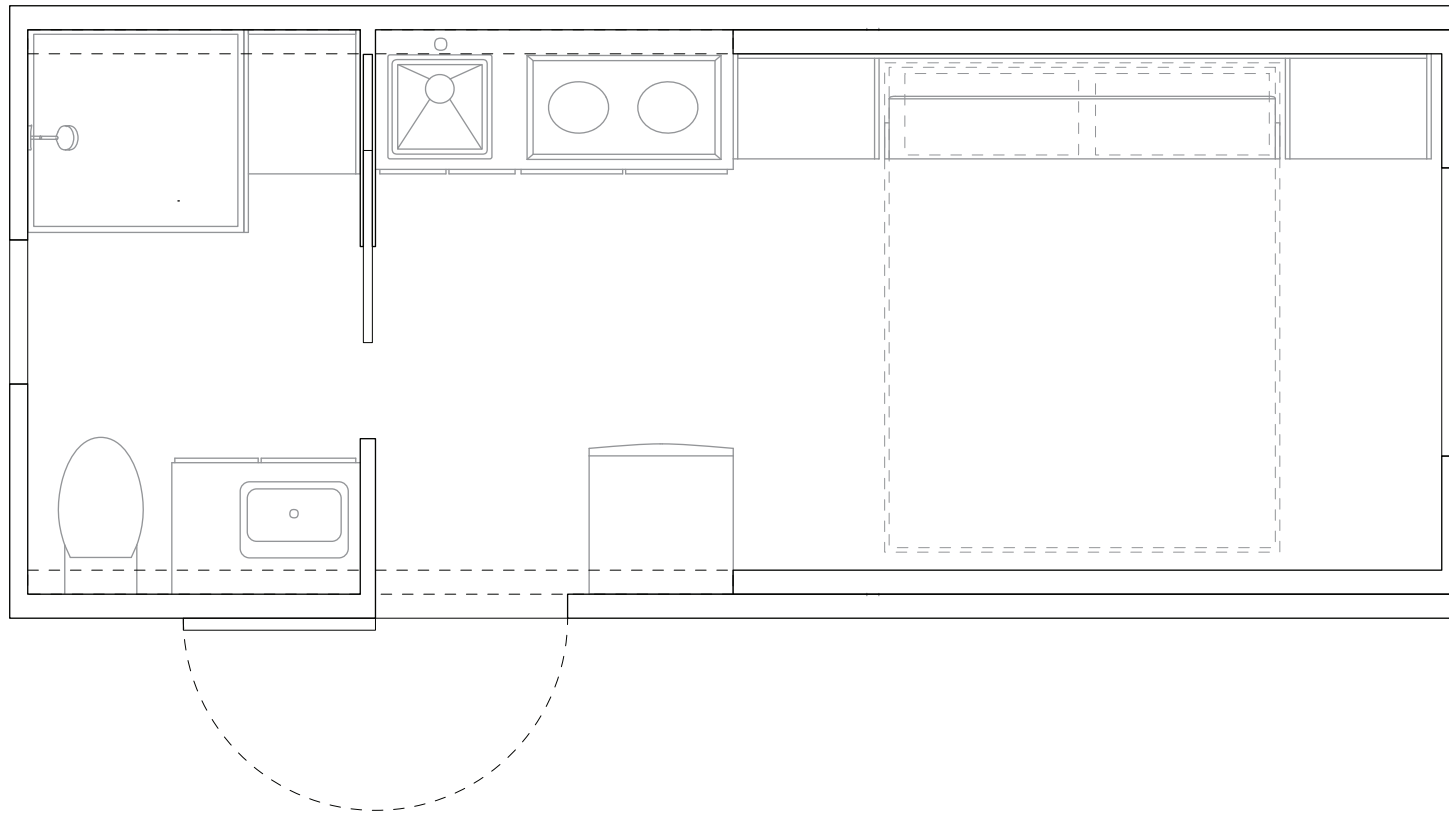

mobile housing module | plan



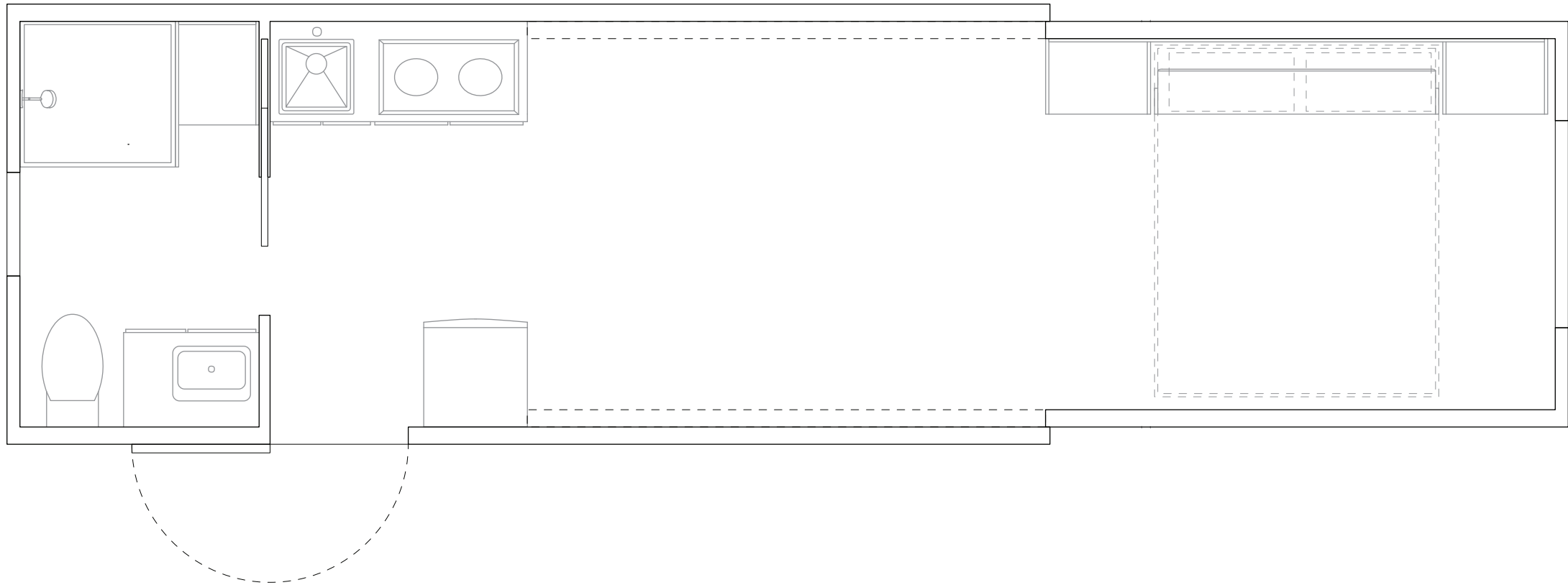

mobile housing module | plan expanded



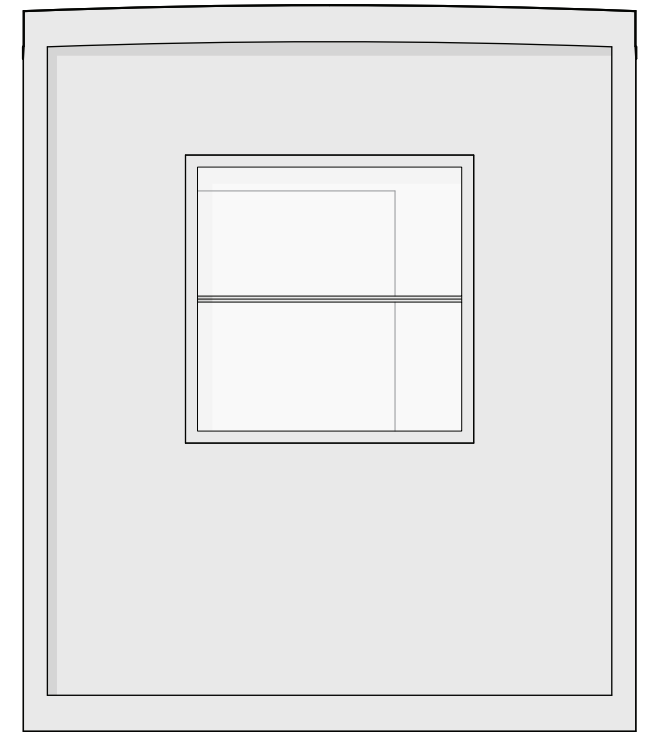

mobile housing module | elevation



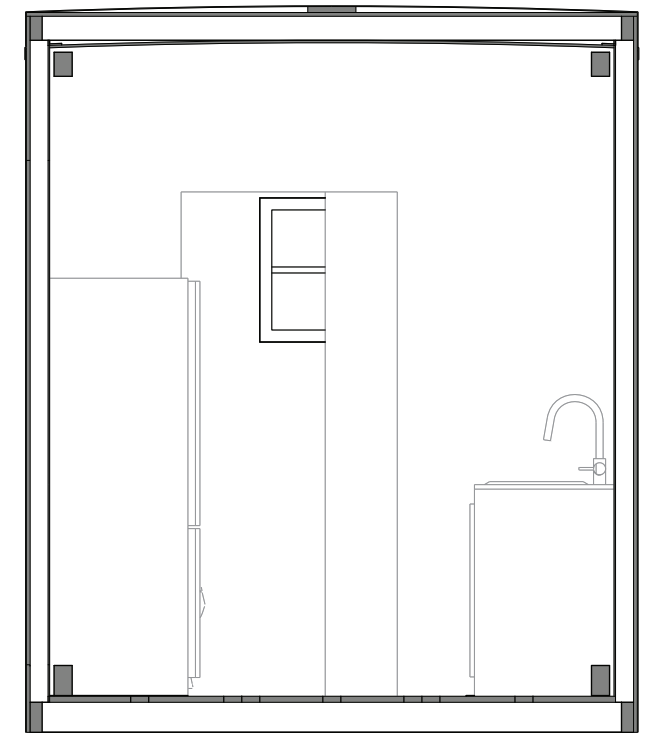
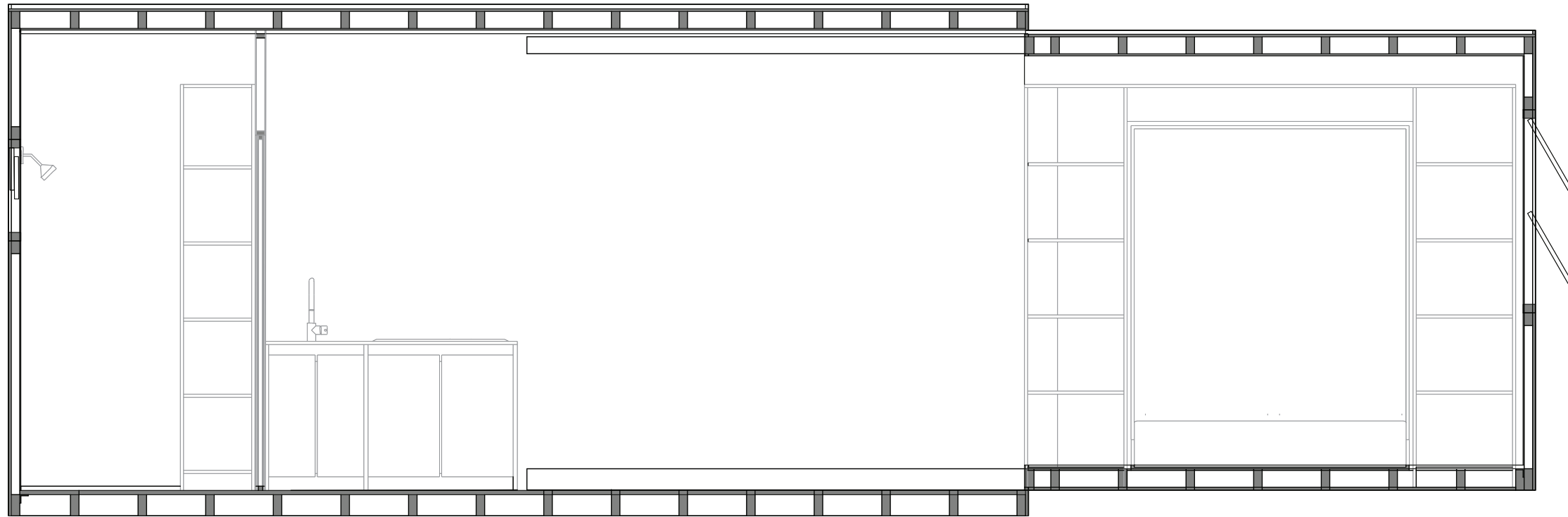

mobile housing module | section



aluminum siding
3/4" sheathing
steel structure
1/2" plywood panel
steel cleat
1/2" plywood panel
steel structure
3/4" sheathing
aluminum siding
door

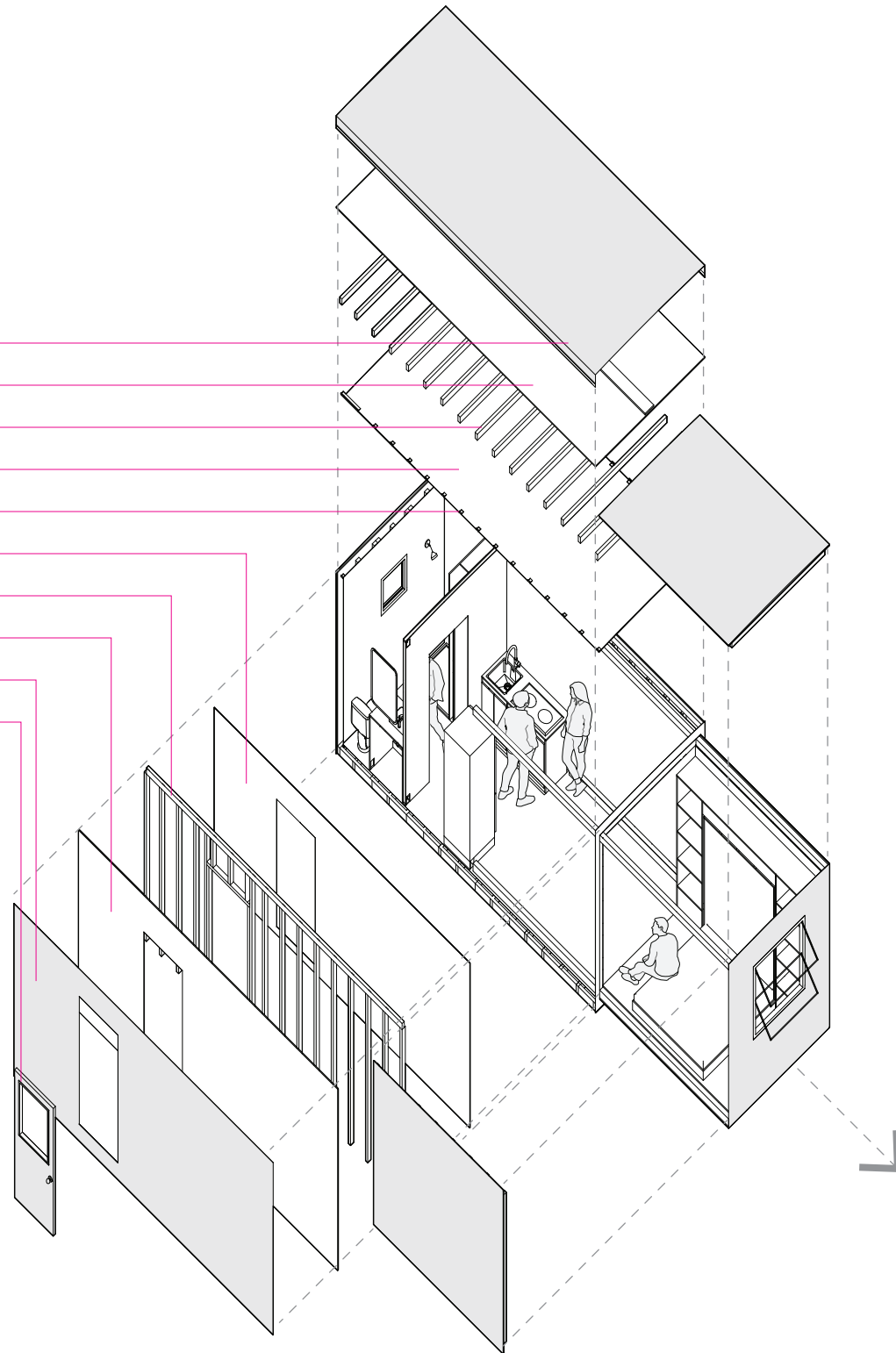

mobile housing module | exploded

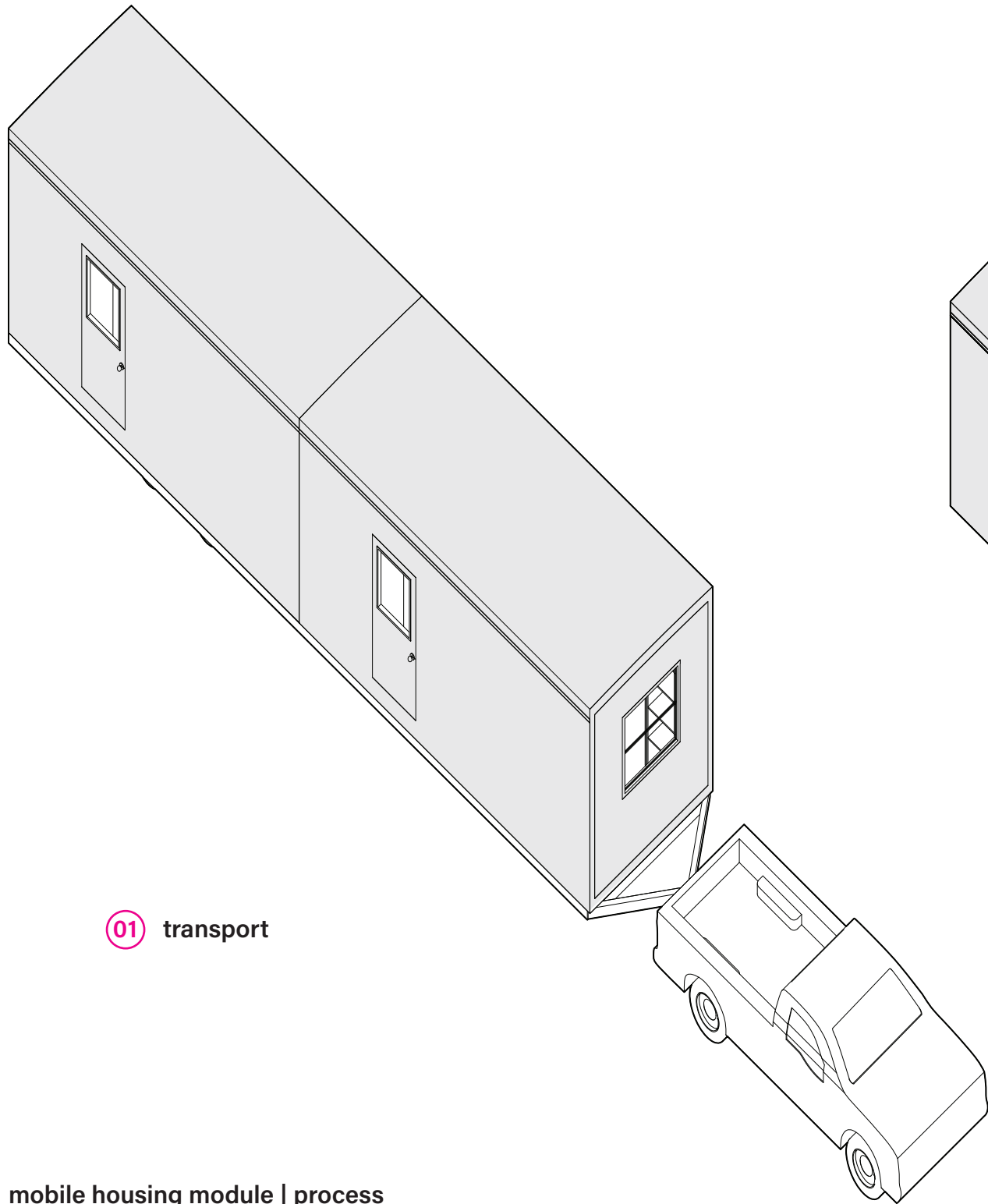

01 transport

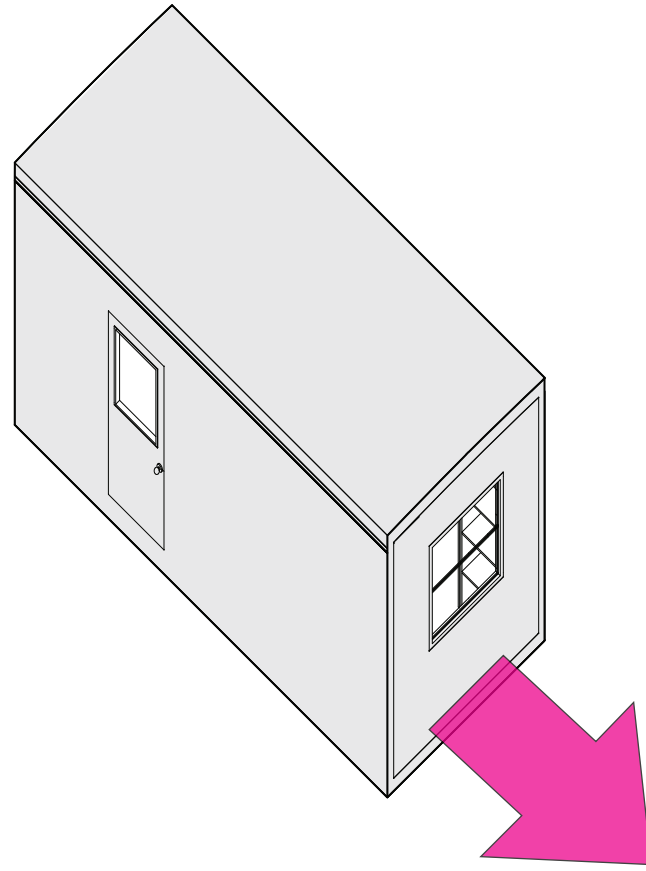

02 place

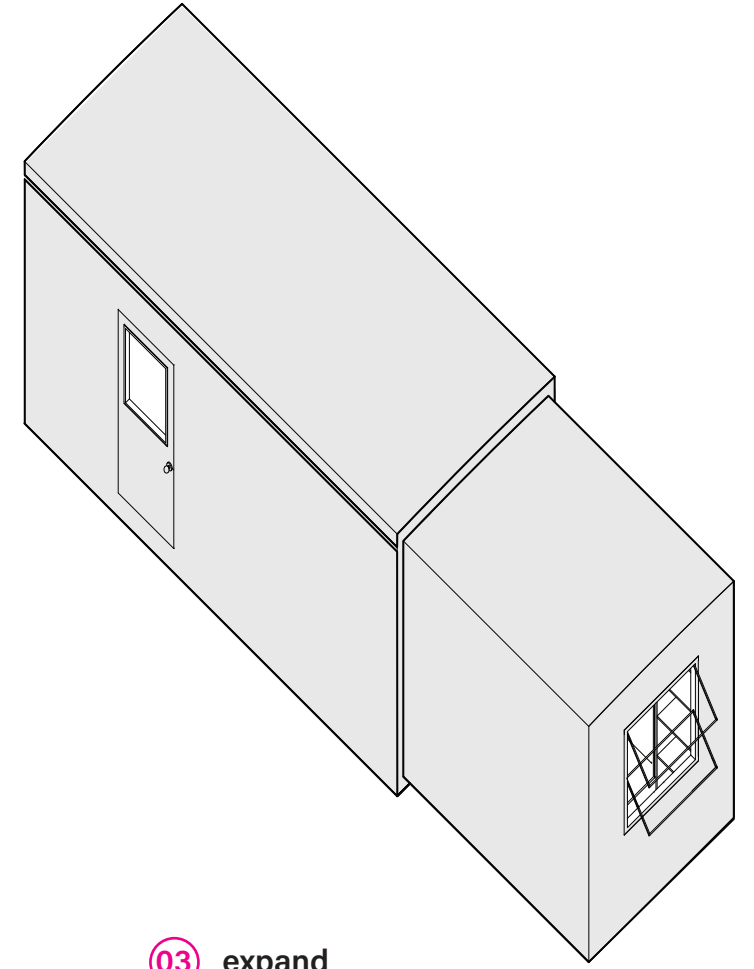

03 expand

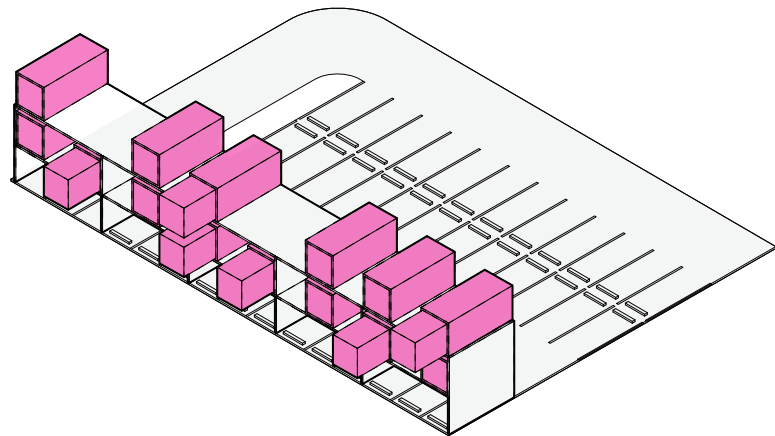

01 surface parking (lot)

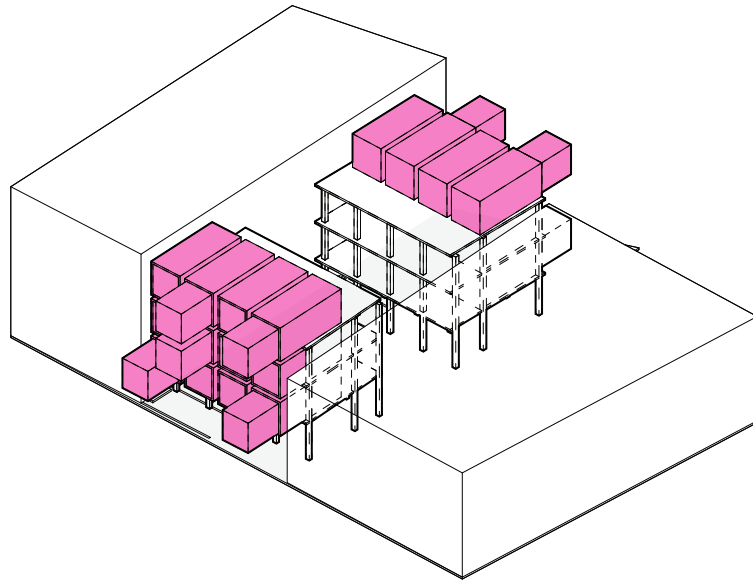

02 surface parking (infill)

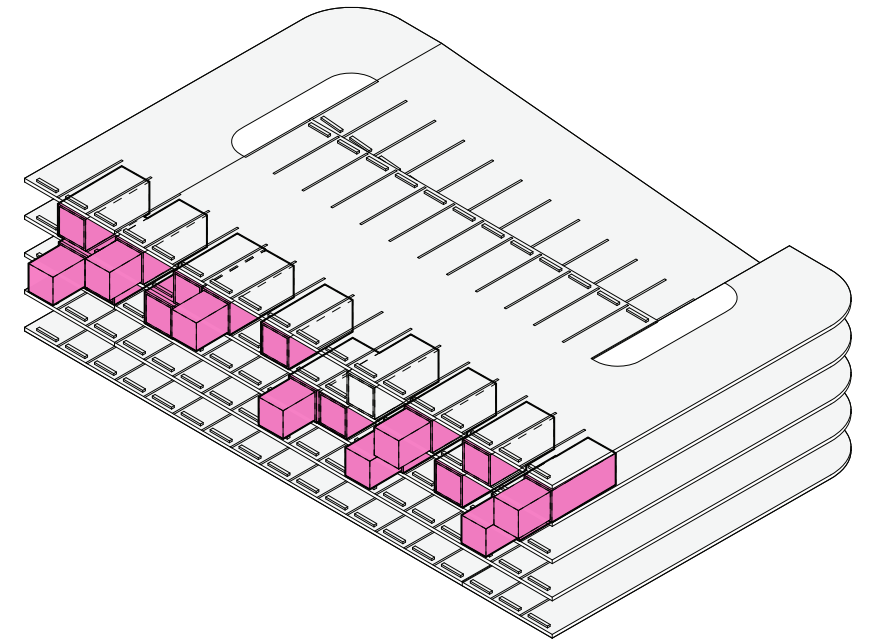

03 parking structure (stacked)



parking + module | study area

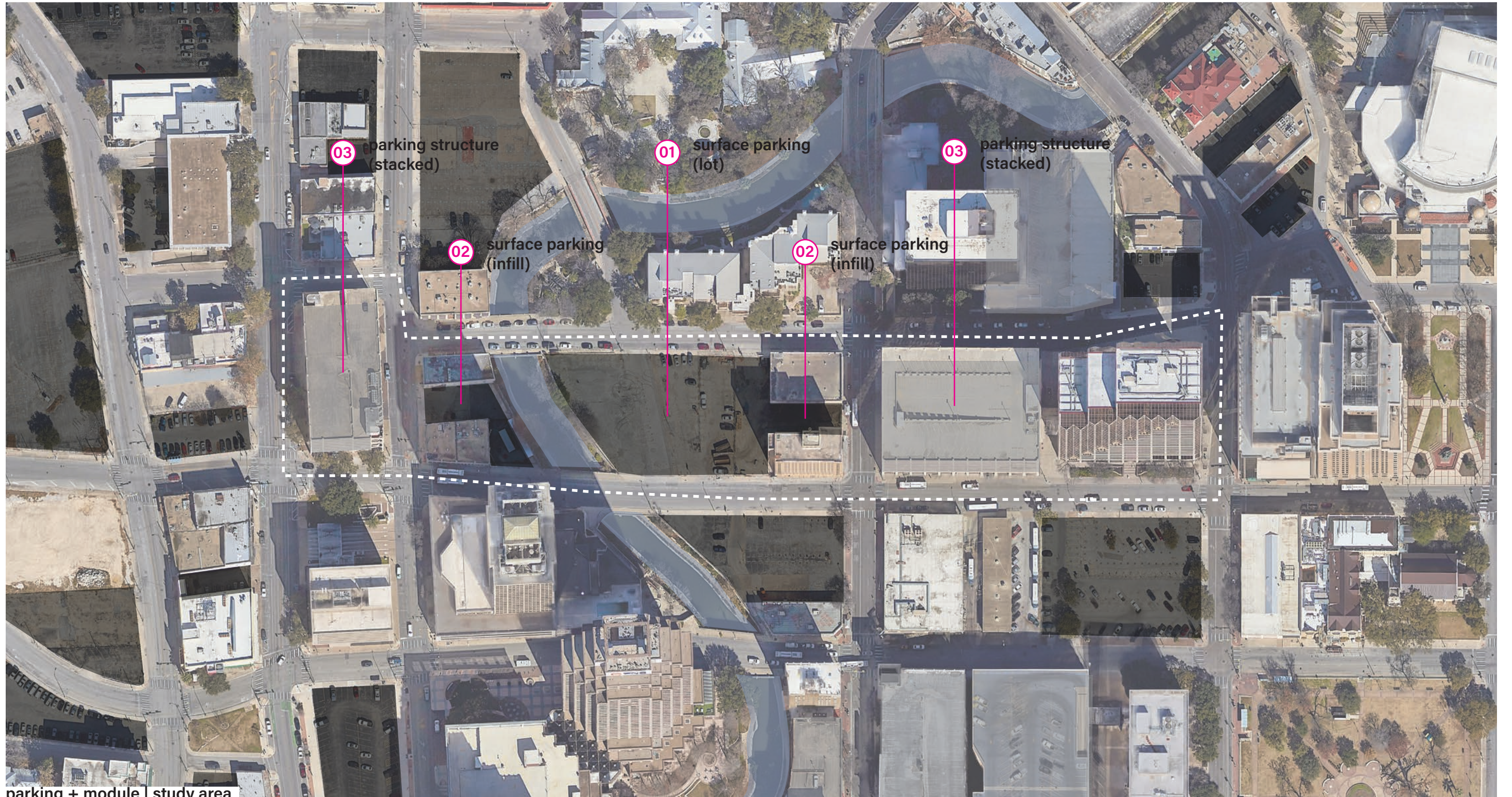

parking + module | study area

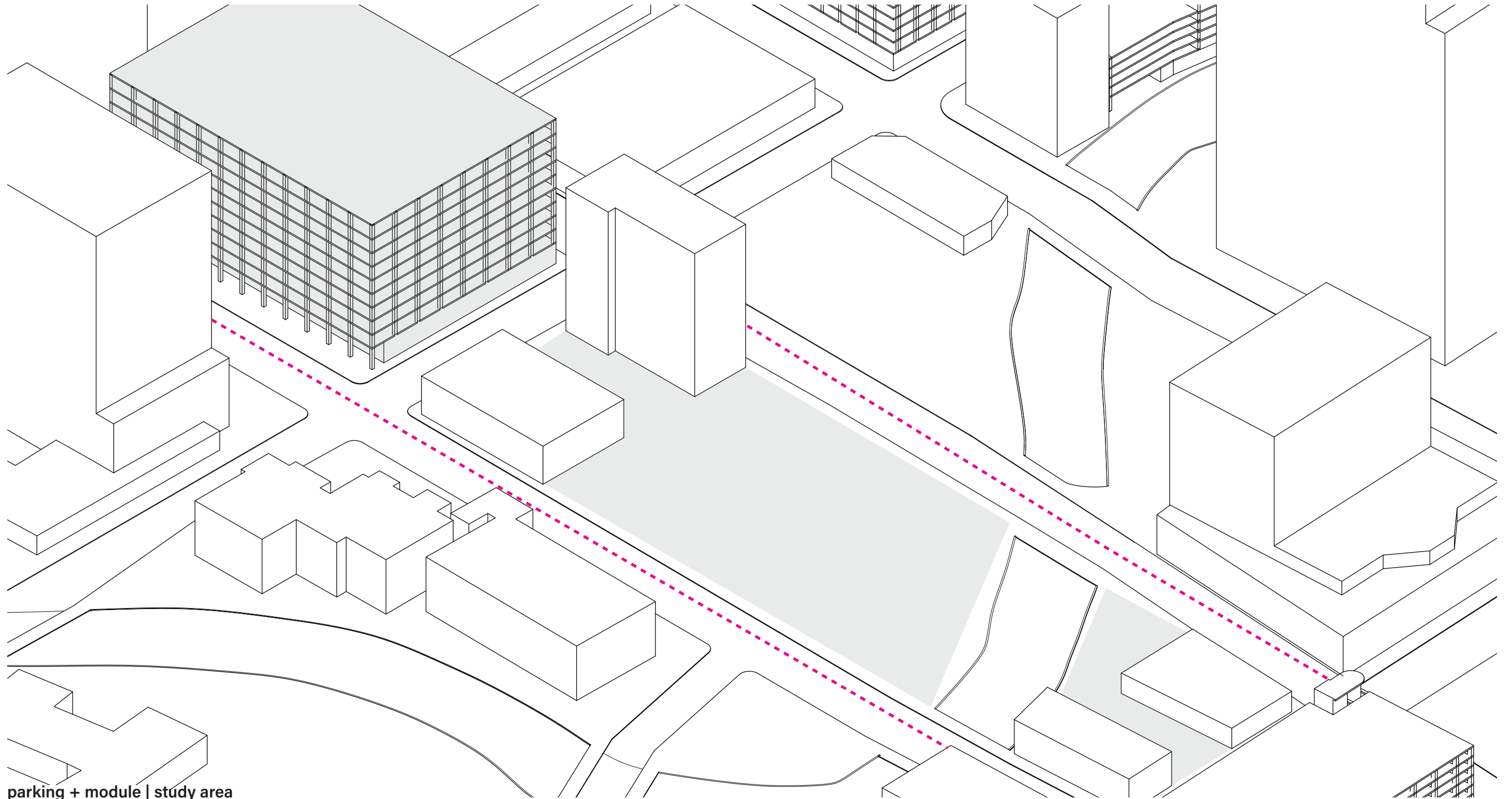

parking + module | study area

